

Physicochemical Characterization of Binary Ionic Polymer Blends: Polyvinyl Acetate Phthalate and Eudragit E PO

PURPOSES

Polymer complexes, such as interpolyelectrolyte complexes, form readily between most polyanions and polycations; these complexes are formed by the ionic association of repeating units on the polymer chains.¹ The aim of this study was to investigate the possible interaction between an anionic polymer (polyvinyl acetate phthalate [PVAP]) and a cationic polymer (basic butylated methacrylate copolymer). The polymer miscibility, PVAP dissolution and physicochemical properties of blends were evaluated.

METHODS

Materials and Matrix Preparation

The chemical structures of PVAP (Phthalavin[®], Colorcon Inc., Harleysville, PA) and basic butylated methacrylate copolymer (Eudragit E PO, Evonik Industries, Darmstadt, Germany) are shown in Figure 1. Both polymers were screened using an ASTM #40 mesh (420 μm) and then blended in a 4-oz jar (VWR, USA) in the weight ratios of 1:1 to 6:1 for 15 minutes using a shaker (Red Devil 5400, Red Devil Equipment Co., USA). The powder blends and neat ionic polymers were compressed into matrix tablets (300 mg) using 10 mm round flat-face tooling at 10 kN (127 MPa) on a single station manual tablet press (Globe Pharma Inc., USA).

Figure 1. Molecular Structures of (A) Polyvinyl Acetate Phthalate and (B) Eudragit E PO

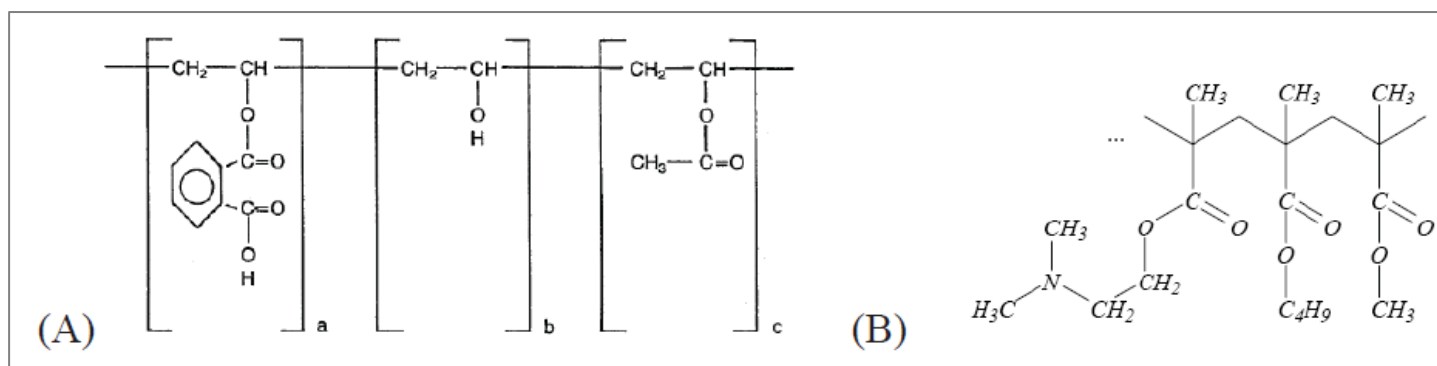

Characterization

Polymer blends in powder and/or tablet forms were characterized using Fourier transform infrared spectroscopy (Nicolet iS10 FT-IR Spectrometer, Thermo Scientific, USA) for chemical bond identification, and modulated differential scanning calorimetry (MDSC, Q2000, TA Instruments, USA) for glass transition temperature and polymer miscibility.

Binary blend tablets were analyzed for release of PVAP using USP Apparatus II, paddle with sinkers, in 1000 mL of dissolution media (pH 1.2, pH 5.5 acetate or pH 6.8 phosphate buffer) at 100 rpm and $37.0 \pm 0.5^\circ\text{C}$. PVAP was detected using an Agilent 8453UV-visible spectroscopy (Agilent Technologies, USA) in wavelength range of 220-320 nm, fitted with quartz flow cells of 2.0 mm path length.

RESULTS

Physical Properties of Powder Blends and Tablets

The FT-IR spectra and MDSC curves of binary PVAP-EPO blends are shown in Figure 2. The results indicated that there were no shifts or additional peaks in the IR spectra, suggesting no chemical interactions between PVAP and EPO in the dry state. In addition, there were two distinct glass transition temperatures found in MDSC curves of all blends, indicating non-miscibility of the polymers in the dry state.

The physical properties of the compacts (tablets) are shown in Table 1. All tablets showed acceptable properties in terms of hardness and low weight variation. Neat PVAP and binary blends resulted in much harder tablets than neat EPO, indicating good compressibility properties of the PVAP.

Figure 2. PVAP-EPO Powder Blends: (A) FT-IR Spectra; (B) MDSC Curves

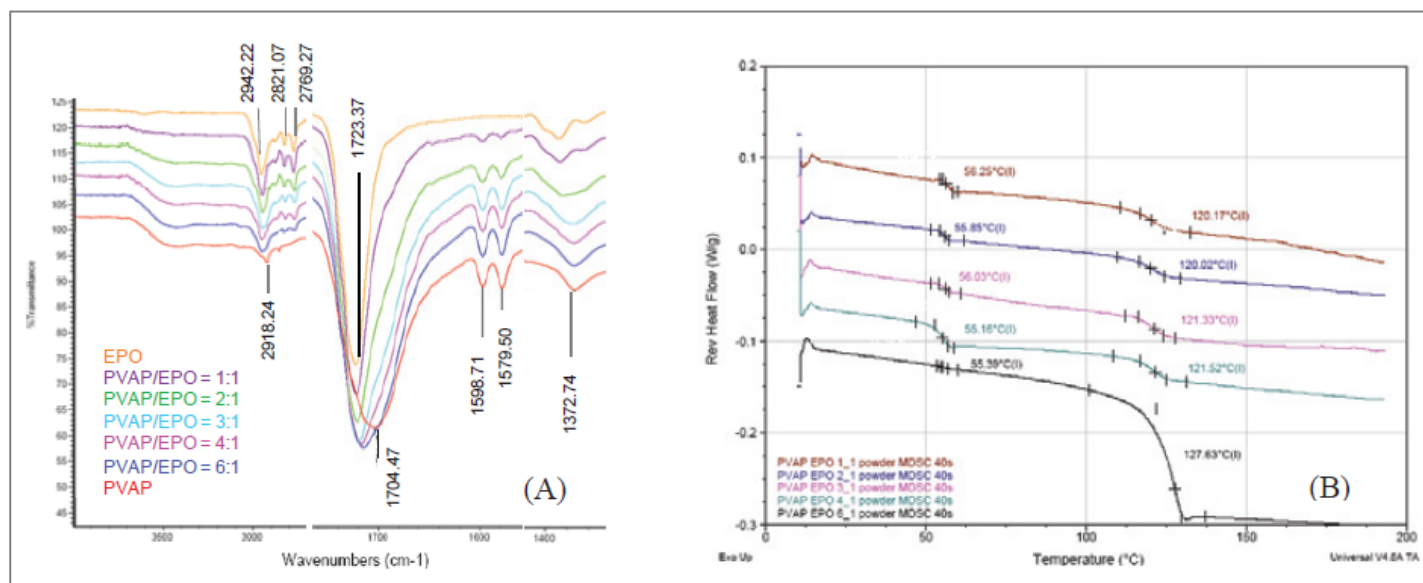

Table 1. Physical Properties of Binary PVAP-EPO Matrices (n = 10)

Formula	Ratio of PVAP/EPO*	PVAP (%)	Weight Variation (%)	Hardness (kp)	Tensile Strength (MPa)
P1	1:1	50.0	0.22	47.5± 0.1	8.63 ± 0.02
P2	2:1	66.7	0.43	45.7 ± 0.1	8.30 ± 0.02
P3	3:1	75.0	0.22	>47.8	>8.68
P4	4:1	80.0	0.43	>47.8	>8.68
P5	6:1	85.7	0.27	>47.8	>8.68
Control 1	PVAP	100.0	0.51	47.8 ± 0.1	8.68 ± 0.02
Control 2	EPO	0.0	0.84	22.6 ± 0.1	4.11 ± 0.02

Note: Constant tablet weight of 300 mg was used

PVAP Dissolution Profiles

The PVAP dissolution profiles in pH 5.5 acetate buffer and pH 6.8 phosphate buffer are shown in Figure 3. PVAP was not detectable in pH 1.2 medium, which could be attributed to its insolubility in low pH acidic media. Dissolution profiles in pH 5.5 acetate buffer indicated that PVAP was released slowly from all the formulations. PVAP release from P1 formulation (PVAP/EPO=1:1) was not quantifiable, mainly due to the interference of white insoluble particles eroded from matrix tablets. Interestingly, in pH 6.8 phosphate buffer, PVAP dissolution rates decreased with increasing PVAP concentration and reached a threshold at polymer ratio of 4:1. In comparison, faster PVAP dissolution rates were observed in pH 6.8 than in pH 5.5 buffer, which may be attributed to the lower PVAP solubility in pH 5.5 (6.3 mg/mL in pH 6.8 phosphate buffer vs. 0.66 mg/mL in pH 5.5 acetate buffer).

Figure 3. PVAP Dissolution Profiles in pH 5.5 Acetate Buffer and pH 6.8 Phosphate Buffer (n=3)

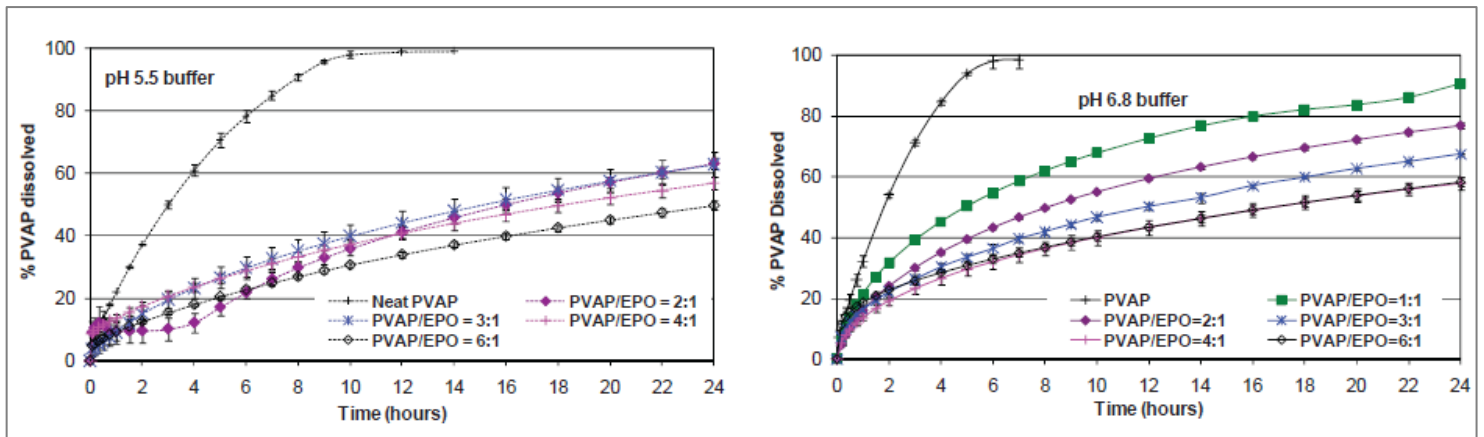

As shown in Figures 4 (A) & (B), similar FT-IR spectra were observed for both PVAP and EPO when placed in pH 1.2, pH 5.5 acetate or pH 6.8 phosphate buffers for two hrs. These FT-IR spectra indicated that carboxylic acid groups of PVAP and/or methylamino groups of EPO stayed intact, and no peak shifting was observed when the neat polymers were placed in dissolution media. The FT-IR spectra of matrix tablets after 24-hr dissolution testing in pH 5.5 acetate and pH 6.8 phosphate buffer are shown in Figures 5 (A) & (B) and 6 (A) & (B), respectively. In Figure 5(A), two peaks have shifted (C-C ring vibration 1599 to 1589 cm⁻¹, carboxylate salt formation 1579 to 1567 cm⁻¹)^{2,3}, one enhanced peak (COO⁻ at 1372 cm⁻¹)² and diminishing peaks (methlamino at 2821-2770 cm⁻¹)^{2,3} were found on tablet surface regardless of polymer ratios. In Figure 5(B), carboxylic acid groups (1579 cm⁻¹)² were observed in the tablet core of all binary matrix tablets, indicating that PVAP probably stayed intact inside the core due to low solubility and lack of media penetration inside the core. Similar peak changes were noticed in Figures 6(A) & (B), except carboxylate salt peak was only observed inside the tablet core at polymer ratio of 1:1, suggesting stronger medium penetration in pH 6.8 than pH 5.5 buffer. These FT-IR spectra are consistent with PVAP dissolution profiles (Figure 3) – ie, the slower PVAP dissolution rates in pH 5.5 or pH 6.8 might be attributed to the reversible complex formation between the carboxylic acid groups of PVAP and methylamino groups of EPO, as indicated by a new carboxylate salt peak found in FTIR spectra at 1567 cm⁻¹ and the enhanced peak at 1372 cm⁻¹.

Figure 4. FT-IR Spectra of Neat Polymers: Dry Polymer vs. Polymer after 2 hrs. in pH 1.2, pH 5.5 Acetate or pH 6.8 Phosphate Buffer (A) PVAP; (B) EPO

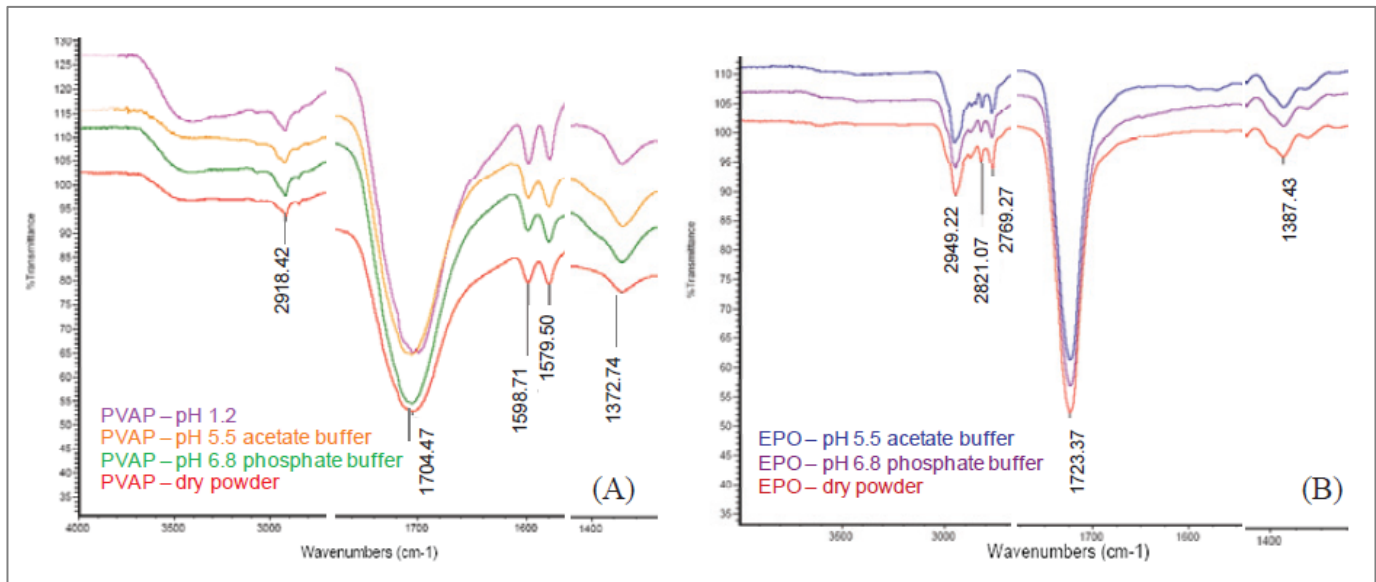

Figure 5. FT-IR Spectra of Tablets After 24-hrs Dissolution Testing in pH 5.5 Acetate Buffer: (A) Surface; (B) Inside Core

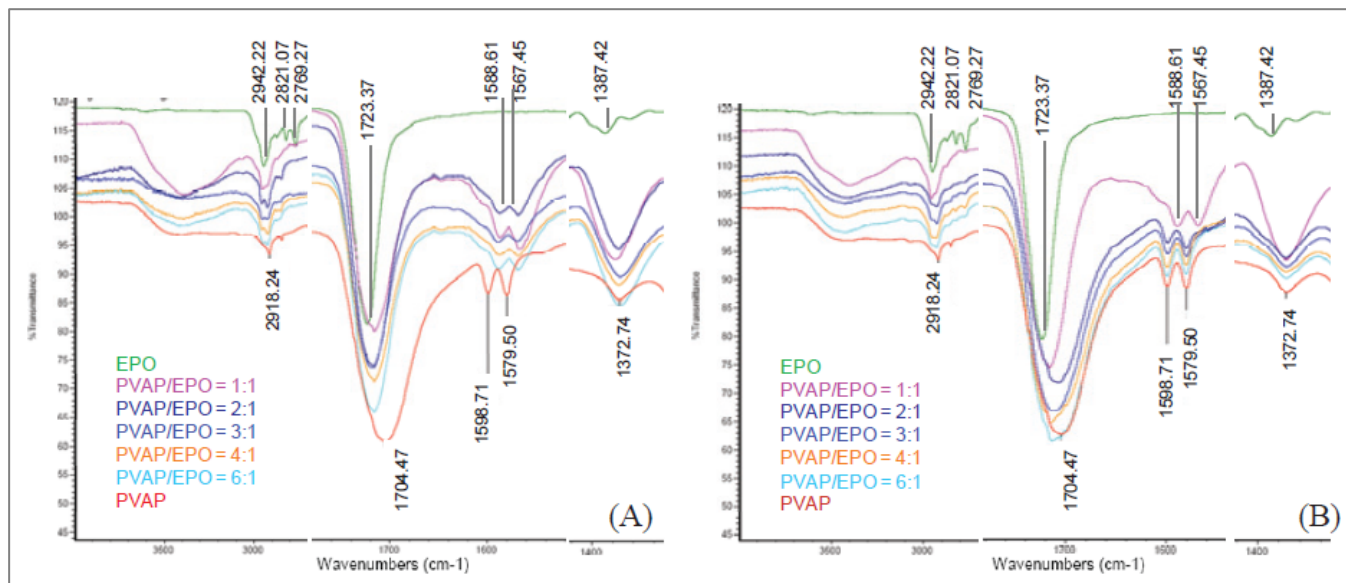
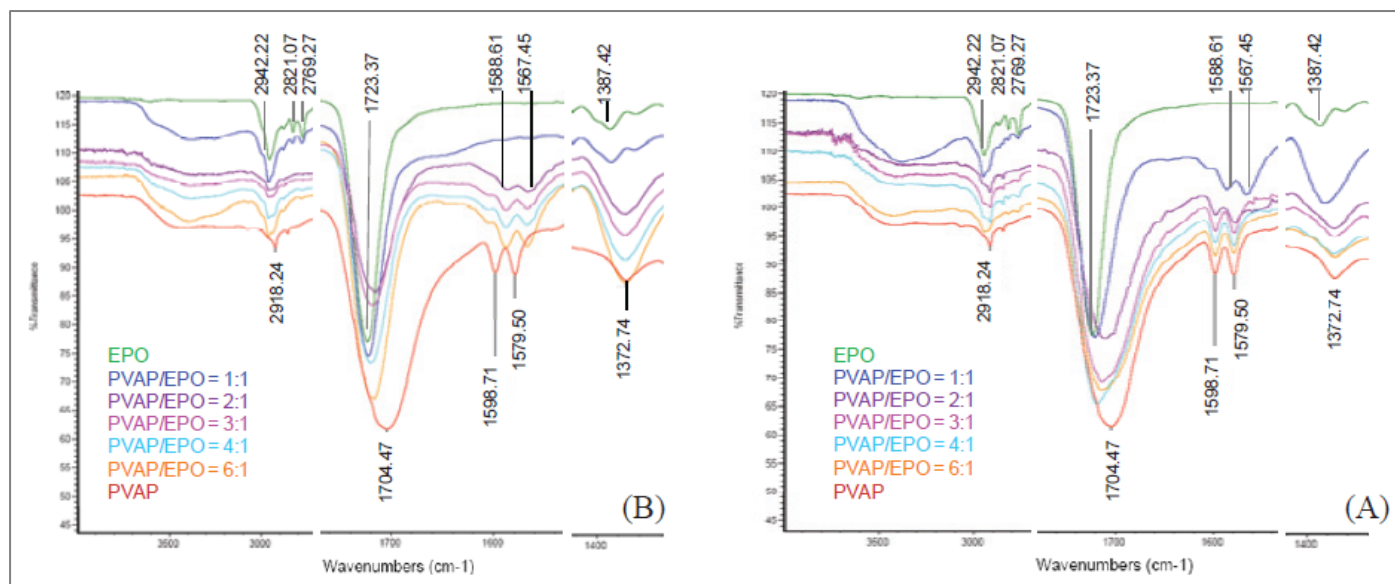

Figure 6. FT-IR Spectra of Tablets After 24-hrs Dissolution Testing in pH 6.8 Phosphate Buffer: (A) Surface; (B) Inside Core



CONCLUSIONS

Ionic interaction between PVAP and EPO was identified when blended polymers were exposed to pH 5.5 acetate or pH 6.8 phosphate media. This interaction was not evident in dry powder blends or compressed tablets. This ionic interaction may be explored further in the formulation of a binary PVAP-EPO carrier for use in design of pharmaceutical dosage forms, where in situ interpolyelectrolyte complex formation may allow extended drug release.

Reprint of poster presented at AAPS 2010. Authors: Hua Deng (Colorcon), Anthony J. McHugh (Lehigh University) and Ali Rajabi-Siahboombi (Colorcon)

REFERENCES

1. Lowman, M.A., Complexing polymers in drug delivery, in: Handbook of Pharmaceutical Controlled Release Technology, Marcel Dekker, New York, USA, 2000, 89-98.
2. Del Fanti, N.A., Infrared Spectroscopy of Polymers, Thermo Fisher Scientific, Madison, WI, 2008.
3. Menjoge, A.R., Kulkarni, M.G., Mechanistic investigation of phase behavior in Eudragit® E blends. International Journal of Pharmaceutics, 2007; 343: 106-121.

The information contained herein, to the best of Colorcon, Inc.'s knowledge is true and accurate. Any recommendations or suggestions of Colorcon, Inc. with regard to the products provided by Colorcon, Inc. are made without warranty, either implied or expressed, because of the variations in methods, conditions and equipment which may be used in commercially processing the products, and no such warranties are made for the suitability of the products for any applications that you may have disclosed. Colorcon, Inc. shall not be liable for loss of profit or for incidental, special or consequential loss or damages.

Colorcon, Inc. makes no warranty, either expressed or implied, that the use of the products provided by Colorcon, Inc., will not infringe any trademark, trade name, copyright, patent or other rights held by any third person or entity when used in the customer's application.

For more information, contact your Colorcon representative or call:

North America
+1-215-699-7733

Europe/Middle East/Africa
+44-(0)-1322-293000

Asia Pacific
+65-6438-0318

Latin America
+54-11-5556-7700



© BPSI Holdings LLC, 2013.

The information contained in this document is proprietary to Colorcon and may not be used or disseminated inappropriately.

All trademarks, except where noted, are property of BPSI Holdings, LLC.

pR_AAPS_2010_Deng_Physicochemical_charc_ver2_12_2013

You can also visit our website at www.colorcon.com

This document is valid at the time of distribution. Distributed 24-Mar-2023 (UTC)